



ARB® UTILITY MANAGEMENT SYSTEMS™ WATER | GAS | ELECTRIC

# TRU/FLO® Compound Installation and Maintenance Guide



TRU/FLO® COMPOUND INSTALLATION AND MAINTENANCE GUIDE



ARB® UTILITY MANAGEMENT SYSTEMS™ WATER | GAS | ELECTRIC

# TRU/FLO® Compound Installation and Maintenance Guide

This manual is an unpublished work and contains the trade secrets and confidential information of Neptune Technology Group Inc., which are not to be divulged to third parties and may not be reproduced or transmitted in whole or part, in any form or by any means, electronic or mechanical for any purpose, without the express written permission of Neptune Technology Group Inc. All rights to designs or inventions disclosed herein, including the right to manufacture, are reserved to Neptune Technology Group Inc.

Neptune engages in ongoing research and development to improve and enhance its products. Therefore, Neptune reserves the right to change product or system specifications without notice.

## **Trademarks Used in this Manual**

Neptune is a registered trademark of Neptune Technology Group Inc.

Other brands or product names are the trademarks or registered trademarks of their respective holders.

### **Neptune Technology Group Inc.**

1600 Alabama Highway 229  
Tallahassee, AL 36078  
USA

Tel: (800) 645-1892  
Fax: (334) 283-7299

### **Neptune Technology Group (Canada) Ltd.**

7275 West Credit Avenue  
Mississauga, Ontario  
L5N 5M9  
Canada

Tel: (905) 858-4211  
Fax: (905) 858-0428

### **Neptune Technology Group Inc.**

Ejército Nacional No. 418  
Piso 12, Desp. 1201-1202  
Col. Chapultepec Morales  
Delegación Miguel Hidalgo

11570 México, Distrito Federal  
Tel: (525) 55203 5294 / (525) 55203 5708  
Fax: (525) 55203 6503

<b>1</b>	<b>OVERVIEW</b>	
	Contacting Technical Support .....	1-1
<b>2</b>	<b>INSTALLING THE TRU/FLO COMPOUND</b>	
	Installation Instructions .....	2-1
	Recommended Installation .....	2-2
	Before Operation.....	2-3
<b>3</b>	<b>MAINTENANCE</b>	
	TRU/FLO Maintenance.....	3-1
	Calibration Vane Adjustment.....	3-2



## CHAPTER 1 OVERVIEW

Neptune's TRU/FLO® Compounds offer the widest operating range of any compound meter on the market. In order to achieve comparable performance in actual service, it is essential that these installation instructions be understood and followed.

### CONTACTING TECHNICAL SUPPORT

If you encounter any problems with the installation or operation of your TRU/FLO Compound, please call Neptune at (334) 283-6555 and ask to speak with an Applications Engineer.



## CHAPTER 2 INSTALLING THE TRU/FLO COMPOUND

This chapter is designed to take you through the installation process for the TRU/FLO Compound meter.

### INSTALLATION INSTRUCTIONS

All TRU/FLO Compound meters operate more accurately and reliably if installed properly. TRU/FLO Compound meter performance is directly related to the flow conditions of the water stream entering the meter. If the flow conditions are distorted as a result of upstream fittings or piping changes, the TRU/FLO Compound meter performance can be adversely affected.

For example, a properly installed meter with a length of straight pipe equal to 8 to 10 diameters immediately upstream of the inlet would register at 100%. The same meter installed with an elbow fitting immediately upstream of the meter will cause distortions in the flow stream conditions which would make meter performance highly erratic.

Neptune recommends that all TRU/FLO Compound meters be installed with a plate strainer at the meter inlet. The strainer, in addition to protecting the meter from debris in the line, also corrects the velocity profile of the flow to the meter.

When installing Neptune meters with a strainer, a minimum of four (4) pipe diameters of straight run pipe (can include components that are fully open in their normal operating position) is required upstream and downstream of the meter/strainer assembly.

If a Neptune meter is installed without a strainer, a minimum of eight (8) pipe diameters of straight run pipe (can include components that are fully open in their normal operating position) is required upstream of the meter/strainer assembly. A minimum of four (4) pipe diameters of straight run pipe is required downstream of the meter/strainer assembly.

When installing a TRU/FLO Compound meter, the recommended installation instructions should be followed.

**RECOMMENDED INSTALLATION**

The recommended installation of a TRU/FLO Compound meter is shown in Figure 2.1. This installation incorporates a plate-type strainer attached to the inlet of the meter. This illustration also shows an optical bypass which provides uninterrupted service capability during periods of meter service.

As indicated previously, the upstream plate-type strainer provides protection against meter damage from debris in the lines and virtually eliminates the effects of variations in upstream piping. Use of a Neptune strainer of the same line size as the meter is specifically recommended. This strainer design provides optimum velocity profile correction at minimum additional head loss.

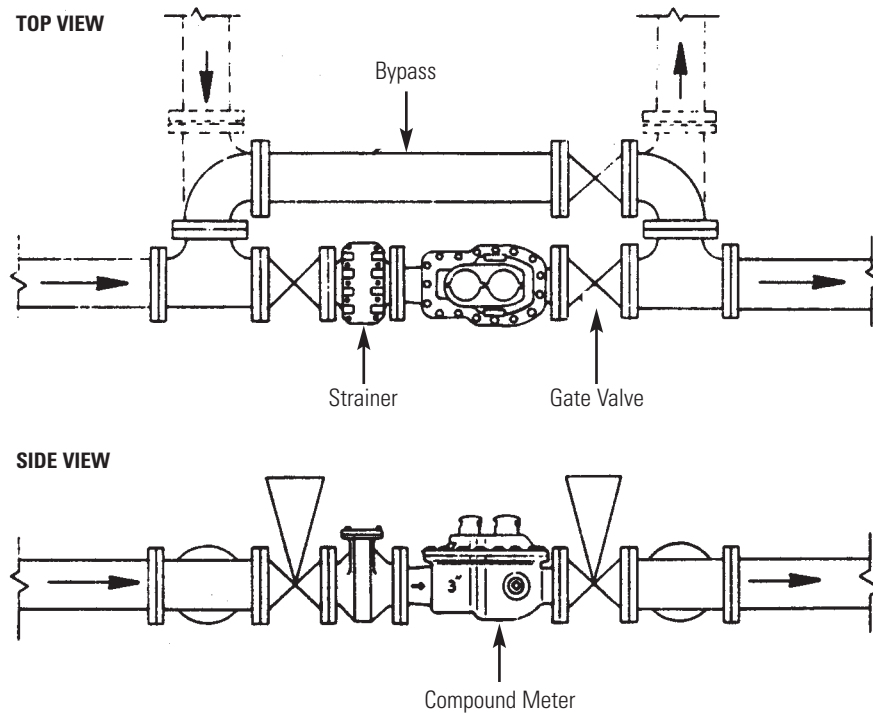

**FIGURE 2.1 TRU/FLO COMPOUND TOP AND SIDE VIEW**



When installing a TRU/FLO Compound meter, normal good piping practice should always be followed. In particular, all gaskets should be centrally located on their flanges with no overlap or interference with the pipe diameter. This is particularly important at the inlet connection to the meter where a gasket protruding into the flow stream will cause unpredictable velocity conditions.

TRU/FLO Compound meters must operate in a completely filled line at all times. The downstream piping must always provide sufficient back pressure to maintain a full line at the meter.



Caution should be exercised to avoid air in the line, sudden flow surges, or excessive flow rates since these conditions may cause severe damage to the meter.

#### BEFORE OPERATION

Before putting the TRU/FLO Compound meter in service follow these steps:

- 1 Turn air bleed on meter cover counter-clockwise one to two turns.
- 2 With outlet-side gate valve closed, SLOWLY open inlet-side valve to pressurize meter.
- 3 Close air bleed screw (clockwise) when air is completely vented and no “spitting” occurs.
- 4 SLOWLY open outlet-side gate valve until downstream is pressurized.



After installation, it is important that the upstream (inlet) valve be put in the “full open” condition during service. A partially throttled upstream valve will cause flow profile distortion which will adversely affect meter accuracy. All throttling should be done ONLY on the downstream (outlet) side of the meter.



## CHAPTER 3 MAINTENANCE

If you find that your TRU/FLO Compound is not operating as expected when installed, use the following guidelines to try to determine the source of the problem.

### TRU/FLO MAINTENANCE

When maintenance is necessary, the complete measuring element (Figure 3.1 - TRU/FLO Registers, Cover, Turbine Cage and Chamber) may be quickly and easily interchanged with a factory calibrated unit. The main valve and throttle valve assemblies may also be quickly replaced if required.

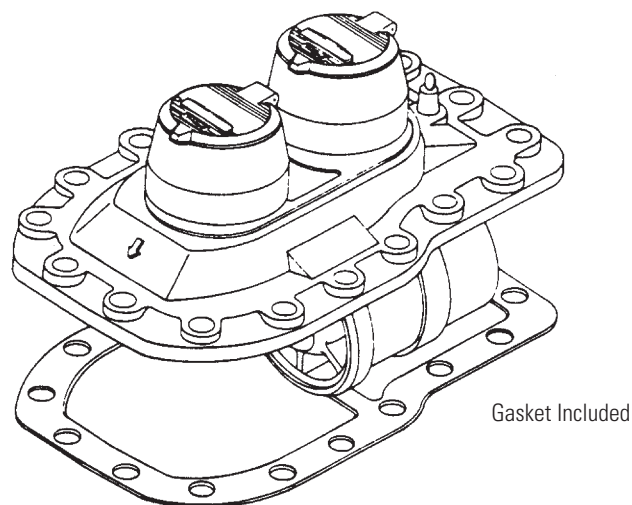

**FIGURE 3.1 TRU/FLO REGISTERS, COVER, TURBINE CAGE AND CHAMBER**

- 1 Close valves.
- 2 Remove cover bolts.
- 3 Remove Cover Assembly. On 2" & 3" meters screwdriver slots are provided to loosen cover and the register boxes provide lifting handles. On 4" & 6" meters 2-3 8-16 tapped holes are provided for jack screws or eye bolts.
- 4 Inspect main valve, throttle valve and throttle valve seal. Replace if defective.
- 5 Remove old maincase gasket and replace with new gasket. Make sure throttle valve and seal are properly seated.

- 6 Install factory calibrated cover assembly into maincase. Be careful not to disturb seal ring on outlet cage during assembly.
- 7 Replace cover bolts
- 8 Tighten cover bolts
- 9 Open valve-follow procedure described under "Before Operation" on page 2-3.

All unitized measuring elements have been factory calibrated and should not require field calibration (refer to meter installation instructions).

The complete measuring unit should be returned for service to Neptune. If the customer does not have a spare unit, a factory calibrated exchange unit may be purchased from your Neptune representative. Neptune encourages all customers to purchase either a spare measuring unit complete or a blank cover to enable them to avoid service interruptions.

#### **CALIBRATION VANE ADJUSTMENT**

Should field calibration of the turbine element be required, the following steps should be taken:

- 1 Cut seal wire and remove tamper-resistant cap.
- 2 Loosen lock nut by turning counter-clockwise.
- 3 Insert slotted screwdriver into slot in top of adjusting stem, and:
  - a. Turn clockwise to decrease registration; or
  - b. Turn counter-clockwise to increase registration.



Turning the adjustment stem 3" in either direction results in approximately 1% change in registration. The full range of the calibration vane is 30°.

**Neptune Technology Group Inc.**

1600 Alabama Highway 229  
Tallahassee, AL 36078  
USA

Tel: (800) 645-1892  
Fax: (334) 283-7299

**Neptune Technology Group (Canada) Ltd.**

7275 West Credit Avenue  
Mississauga, Ontario  
L5N 5M9  
Canada

Tel: (905) 858-4211  
Fax: (905) 858-0428

**Neptune Technology Group Inc.**

Ejército Nacional No. 418  
Piso 12, Desp. 1201-1202  
Col. Chapultepec Morales  
Delegación Miguel Hidalgo  
11570 México, Distrito Federal

Tel: (525) 55203 5294 / (525) 55203 5708  
Fax: (525) 55203 6503



**NEPTUNE**  
TECHNOLOGY GROUP  
**TAKE CONTROL**

[neptunetg.com](http://neptunetg.com)